

Automatic Wall-mounted Stainless Steel Washbasin Tap SLU 43B

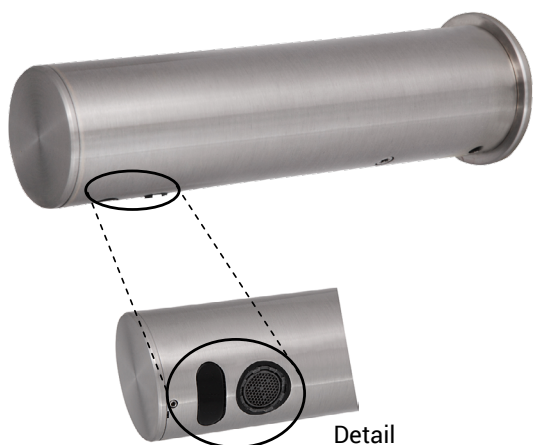

Detail

Characteristics



- economical aerator, rate of flow 6 l/min
- hygienic flush
- lead free
- is destined for cold or premixed water
- water is flowing as long as hands are in the active range
- water stops flowing after removal of hands from the active range sensor after adjustable time delay (can be set in range 0,25 - 7,75 s)
- function of automatic water stop after 5 minut of continuous flow
- monitoring of battery capacity (for models with index B)
- START/STOP program
- parameter adjustment using by the remote control SLD 03

Installation Drawing

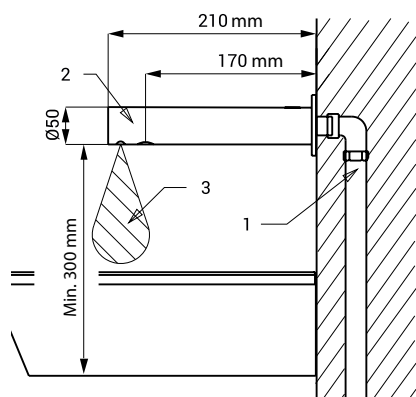

- 1 - water supply
2 - spout
3 - active range

Technical Specification

Operating voltage	6 V
Power input	2 W
Battery life	
▪ 4 pcs. AA alkaline batteries AA, 1,5 V, 2700 mAh	approx. 2 years (100 uses per day)
Active range	
▪ standard	0,11 - 0,15 m
▪ START/STOP program	0,05 - 0,15 m
Recommended flow pressure	0,1 - 0,6 MPa
Rate of flow	6 l/min. (inf. data)
Water inlet	male thread G 1/2"



SLZN 83E - automatic wall-mounted soap dispenser

Supply Specification

SLU 43B - Supply No. 03435 faucet with electronics and electromagnetic valve, 4 pcs. AA alkaline batteries 1,5 V, 2700 mAh

Recommended Accessories

SLD 03	- Supply No. 07030	remote control for an adjustment of parameters
SLT 04	- Supply No. 09040	thermostatic valve 3/4", rate of flow 28 l/min by the pressure 0,1 MPa
SLT 05	- Supply No. 09050	thermostatic valve 1/2", rate of flow 42 l/min by the pressure 0,1 MPa
SLR 24	- Supply No. 08240	mounting frame for soap dispenser SLZN 83E
SLA 36	- Supply No. 06360	set of 4 pcs. alkaline batteries AA, 1,5 V, 2700 mAh
SLZN 83E	- Supply No. 85830	automatic wall-mounted soap dispenser